

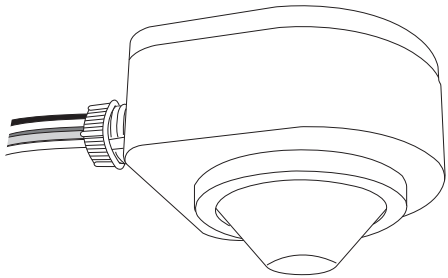

SEN-3A-KO

Line Voltage Occupancy Sensor

INSTALLATION INSTRUCTIONS



*Other lens options are available, please refer to Lens Installation Sheet for appropriate option.

⚠ WARNING & CAUTION

- Risk of Electric Shock - Disconnect power supply before servicing.
- Do NOT touch the square window of infrared sensor under the lens assembly.
- Open Type Photoelectric Switches.

OVERVIEW

The SEN-3A-KO is a line voltage switching occupancy sensor designed for all-purposes energy efficient lighting control.

This occupancy sensor employs a cutting edge quad element pyroelectric infrared sensor to provide omni-directional sensing capability of occupant's presence and movements. The digital potentiometer makes the sensor setting easier, faster and more accurate than the conventional analog potentiometer. An exclusive Hybrid Switching technology makes the SEN-3A-KO ideal to control the lighting with exceptionally high inrush current (HIC) while switching on, such as multiple LED or CFL lightings connected in parallel.

The SEN-3A-KO is available with various mounting options and interchangeable lenses. This provides a second-to-none design and complete installation flexibility. The sensor is designed to operate in the coldest of environments, down to -40°C/°F.

The SEN-3A-KO comes with an ambient light sensor (ALS) to inhibit the lighting if ambient light levels are higher than required. The SEN-3A-KO is designed to provide complete occupancy sensing for automatic lighting control, ease of use, and the simplest installation possible.

⚠ AVERTISSEMENT & PRUDENCE

- Risque de choc électrique - Débranchez l'alimentation avant l'entretien.
- Ne PAS toucher la fenêtre carrée de capteur infrarouge sous l'ensemble de l'objectif.
- Ouvrir Type commutateurs optoélectroniques.

INSTALLATION NOTES

1. The sensor is more sensitive to the movements "crossing" the detection zones than "toward" or "away" the sensor unit. To obtain better sensitivity, avoid placing the sensor in line with occupant path, if possible.
2. The closer the movement is to the sensor, the more sensitive the sensor is. The higher the sensor is installed, the larger movement is required to be detected.
3. Ensure to place the sensor at least at 1.5m (5 ft.) away from air supply ducts as rapid air flow may cause false activations.
4. The sensor cannot "see" the movements behind obstacles, such as furniture, shelf, glass or partition. As a general rule, each occupant should be able to clearly view the sensor unit.
5. For open office areas with partition which could block the sensor view to occupant movements, it is best to place the sensors over the intersection of multiple workstations. For large areas of open office or space, place multiple sensors so that there is overlap coverage with each adjacent sensor.

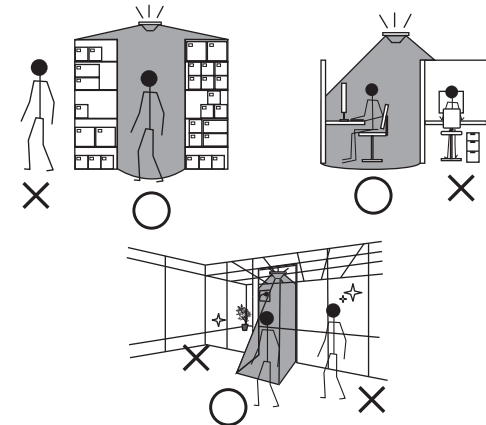

WIRING DIAGRAM

A. Single sensor control

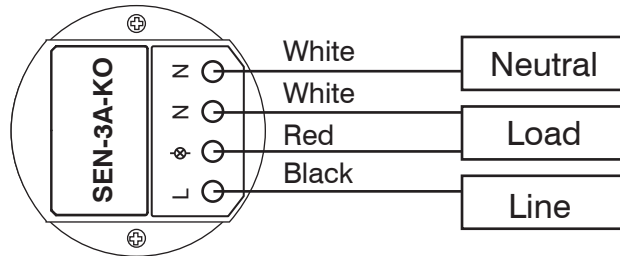

B. Multiple sensors control

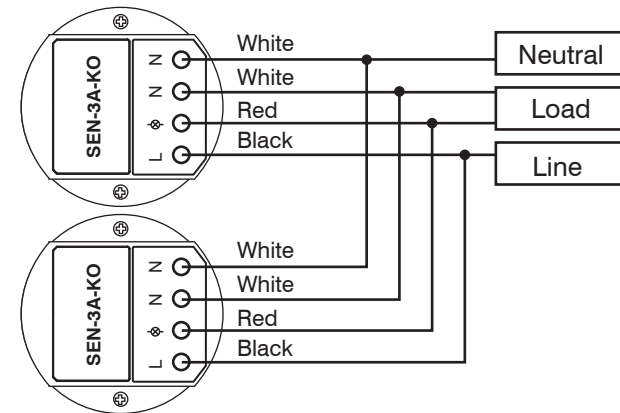

TESTING

Sensor Range Test

1. Ensure the shaft of LUX is set at "7" position.
2. Walk within the desired range* at normal speed. Light should be switched ON as delay time set whenever sensor detects the presence or movement of occupant.
3. The LED indicator behind the lens assembly will blink to indicate sensor detection as well.

* Depending on the lens type ordered and mounting height, the sensor could have different sensing coverage as instructed on the LENS DATASHEET attached.

SENSOR SETTINGS

Delay Time

The SEN-3A-KO offers 7 different delay time selections via potentiometers. The light will remain ON if sensor detects occupant's movement before the set delay time expires.

Ambient Light

The SEN-3A-KO offers 7 different ambient light level selection via potentiometers. The sensor will not switch ON the light if the LUX value of ambient light is higher than set level.

SW. POS.	1	2	3	4	5	6	7
TIME	T	1'	3'	5'	10'	20'	30'
LUX*	12	25	50	90	130	220	24H

Factory Set

SEN-3A-KO

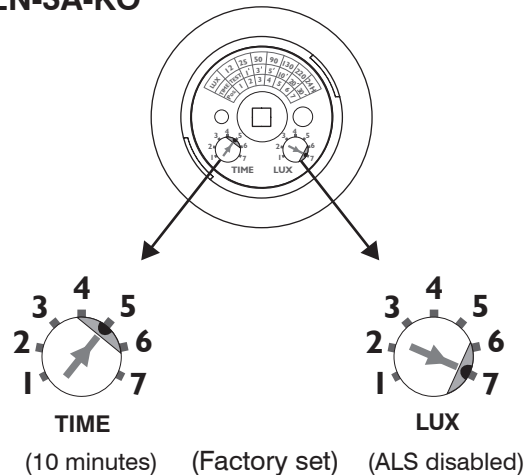

damages with respect to loss of property, revenue, or profit,

SPECIFICATIONS

Power supply	100/120/240/277VAC, 50/60Hz
Maximum Load @ -40°C~55°C (-40°F~131°F-)	Incandescent/Halogen - 800/1200W(VA)@120/277V
	Fluorescent Ballast/CFL - 800/1200W(VA)@120/277V
	Ballast Electronic (LED) - 540/1200VA@120/277V
Maximum Load @ 55°C~70°C (131°F~158°F)	Incandescent/Halogen - 500/750W(VA)@120/277V
	Fluorescent Ballast/CFL - 500/750W(VA)@120/277V
	Ballast Electronic (LED) - 500/750VA@120/277V
Infrared sensor	Omni-directional quad element
Load switching	Zero-cross Hybrid-Switching
HIC protection	Max. 80A for 16.7msec.
Detectable speed	0.3~3m/sec. (1~10 ft./sec.)
Mounting height	Subject to the lens type applied
Detection range	Subject to the lens applied and height
Ambient light level	7 levels digital potentiometer
Delay time setting	T/1'/3'/5'/10'/20'/30', T=10 sec. for testing
Op. humidity	Max. 95% RH
Op. temperature	-40°C~70°C (-40°F~158°F)
Dimensions	Ø60 x H37mm (Ø2.36" x H1.45")

WARRANTY

EiKO Global, LLC warrants this product to be free of defective materials and workmanship for a period of 60 months. EiKO will replace or credit the distributor only for the cost of any product that fails under normal operating conditions due to defective materials or workmanship. This warranty is limited to the replacement or credit of the lamp itself. This is buyer's exclusive remedy. Any other warranty, express or implied, including any warranty of merchantability or fitness for a particular purpose, is excluded and disclaimed. EiKO shall not be liable for any special, incidental or consequential damage including labor, loss of use, lost profits or injury to persons or property.

eiko.com

